



Journal of Educational Sciences

Journal homepage: <https://jes.ejournal.unri.ac.id/index.php/JES>



P-ISSN
2581-1657

E-ISSN
2581-2203

Management of the Semester Credit System (SKS) Program in the Merdeka Curriculum at MAN 2 Pekanbaru City

Rezi Yunizahri*, M. Jaya Adi Putra, Gimin

Master of Educational Administration Program, Postgraduate, Riau University, Pekanbaru, 28127, Indonesia

ARTICLE INFO

Article history:

Received: 17 Nov 2025

Revised: 15 Des 2025

Accepted: 24 Des 2025

Published online: 05 Jan 2026

Keywords:

Management

SKS Program

Independent Curriculum

* Corresponding author:

E-mail: rezi.yuni@student.unri.ac.id

Article Doi:

<https://doi.org/10.31258/jes.10.1.p.178-192>

This is an open access article under the [CC BY-
SA](https://creativecommons.org/licenses/by-nc-sa/4.0/) license.



ABSTRACT

This study aims to determine the management function of the SKS program indicators in the Merdeka Curriculum at MAN 2 Pekanbaru City. This type of research is descriptive qualitative research with data collection techniques through documentation, observation and interviews. The data analysis technique of this research uses the Miles and Huberman model. The results of this study include 1) planning the SKS program at MAN 2 Pekanbaru City including holding meetings, preparing planning documents, mapping students and socializing the SKS program. 2) the organization of the SKS program at MAN 2 Pekanbaru City includes the appointment of the SKS program implementation team, as well as the division of tasks and their respective roles. 3) the implementation of the SKS program at MAN 2 Pekanbaru City includes using the Merdeka Curriculum with a differentiated learning process and providing learning services according to their respective abilities. 4) controlling the SKS program at MAN 2 Pekanbaru City, including the relevance of the SKS program to the vision and mission of the madrasah, supervision is carried out by madrasah supervisors, madrasah heads and deputy heads of academic fields to ensure that the SKS program is implemented according to implementation guidelines and summative and formative assessments are carried out as a form of student learning outcomes.

1. Introduction

Education is one of the main pillars in the development of highly competitive and qualified human resources. One of the problems faced by Indonesia is the low quality of education at every level of the education unit. The quality of education is determined through the input, process and output of education. In line with the times, the Indonesian education system is always undergoing various updates and innovations to answer the increasing challenges of the future. Therefore, it is important to carry out proper program management in an education unit, because

the more qualified the nation's next generation, the higher the quality of education will bring progress to a nation. Management means an activity related to planning, organizing, implementing and controlling which is carried out to determine and achieve goals or ideals that have been set together by utilizing available resources (Eko, 2022).

Through the Indonesian Ministry of Education and Culture, the Indonesian government announced a policy of implementing the Merdeka Curriculum to replace the 2013 Curriculum. One of the objectives of this curriculum change is to improve the previous curriculum to facilitate the achievement of educational goals (Fitriyanti, 2023). The implementation of the Merdeka Curriculum starts from the TK-B/RA, SD / MI, SMP / MTs and SMA / MA levels in 2022/2023. The ability of students to learn to gain knowledge depends on their respective levels of intelligence. The level of intrapersonal intelligence for students is divided into 3 categories, such as (1) below average intelligence, namely students whose learning speed is slow when receiving and processing knowledge, (2) average intelligence, namely students whose learning speed is normal and (3) above average intelligence, namely students whose learning speed is above average (Nisa, 2023).

Based on Indonesian Law No. 20/2003 on the National Education System Article 12 (1) (b) that: "Students in each educational unit have the right to receive educational services in accordance with their talents, interests and abilities, and can complete education according to their respective learning pace" (Depdiknas, 2003). One of the steps in realizing this, the Indonesian government presents an educational program, namely the Semester Credit System (SKS) program, as well as Permendikbudristek No. 7 of 2022 which contains content standards for Merdeka Curriculum materials at the primary and secondary education levels which are also a reference for implementing the Merdeka Curriculum (Sutri, 2023).

Based on the Decree of the Ministry of Education and Culture No. 158 of 2014 concerning the Implementation of SKS in Primary and Secondary Education Article 1 (2) that: "The Semester Credit System, hereinafter referred to as SKS, is a form of education implementation in which students choose the amount of learning load and subjects followed in each semester in an educational unit according to their interests, talents and abilities/speed of learning" (Permendikbud, 2014). According to Oemar in (Sasmito, 2022), the SKS program is an education system that uses semester credit units to report the learning load of students and the workload of teachers.

The presence of the SKS program in the Merdeka Curriculum is a response to educational innovation in the modern era. So that in its implementation, this SKS program is recommended for SBI / RSBI schools that have been accredited "A" from the National Accreditation Board for Schools / Madrasahs (BAN S / M), have guidelines for implementing SKS, qualified Human Resources (HR), adequate learning facilities, have a library with sufficient references and have permission to implement the SKS program from the central government (Naufal, 2020).

The curriculum is required to be more relevant so that it can meet the needs of students in accordance with technological advances and their respective abilities (Fadhila, 2023). The implementation of the SKS program also applies to educational units under the auspices of the Ministry of Religious Affairs based on the Decree of the Director General of Pendis No. 6633 of 2019 concerning Madrasahs Organizing SKS that: “In order to provide quality education services that enable students to complete their studies according to their talents, interests, abilities and learning pace, it is necessary to organize education services with the Semester Credit System (SKS)” (Dirjen Pendis, 2019).

Apart from aiming as an effort to restore learning, the Merdeka Curriculum also helps provide freedom to teachers to choose and customize learning tools according to what is needed by an institution, so that students will later find it easier to understand learning concepts and competencies according to their needs and interests (Aina, 2023). Planning is a fundamental basic function of management. Planning means preparing all the needs, taking into account the problems that arise and formulating the form of implementation of activities that intend to achieve goals (Radjak, 2023).

Management is inseparable from educational institutions. Education management is applied to create a good and effective educational environment (Yunus, 2021). Based on the Decree of the Director General of Education No. 6633 of 2019, MAN 2 Pekanbaru City, which is located on Jalan Diponegoro No. 55, Sail District, Pekanbaru City, is one of the madrasahs designated as the madrasah implementing the SKS program. The process of implementing the SKS program in this madrasah is based on the Decree of the Director General of Education No. 2852 of 2019 concerning Technical Guidelines for the Implementation of SKS in Madrasah Aliyah (MA).

The implemented curriculum consists of several subjects that must be followed by students from start to finish to obtain a diploma (Zamista, 2023). This madrasah has successfully implemented the SKS program learning service since 2019 with a 2-year accelerated study period service program as an effort to deal with students who have above-average intelligence levels, as well as a 3-year normal study period service program as an effort to deal with students who have average and below-average intelligence levels. Then, in the 2023/2024 school year until now MAN 2 Pekanbaru City has integrated the SKS program with the Merdeka Curriculum as an educational service for its students.

This study aims to determine the management function of the SKS program indicators in the Merdeka Curriculum at MAN 2 Pekanbaru City, the implementation of the SKS program with differentiated learning in the Merdeka Curriculum, can provide efficiency and flexibility in improving the development of students' interests and the quality of madrasah. This is also an important value of strengths and opportunities for madrasahs to implement the SKS program in the Independent Curriculum. This research is important to analyze the management of the SKS program in the Independent Curriculum at MAN 2 Pekanbaru City,

because it is a consideration that whether or not it is necessary for madrasas and the government to continue implementing the SKS program in the Independent Curriculum.

2. Methodology

This research method uses a qualitative approach to collect and analyze data obtained naturally (Zuchri, 2021) and research data is collected through documentation studies, observation is an observation with systematic recording of the symptoms studied (Bunga, 2023) and interviews that provide answers to the questions (Moleong, 2019) to find out “Management of the Semester Credit System (SKS) Program in the Independent Curriculum at MAN 2 Pekanbaru City”. The data sources for this research consist of primary data and secondary data. Then, the data obtained is carried out several data analysis steps. according to Miles and Huberman (Sugiyono, 2022) which alludes to data analysis techniques, namely 3 things starting from reduction, then the data is presented and the third is closed with verification or drawing conclusions and validation. It is hoped that the findings of this study will provide a meaningful explanation and analysis.

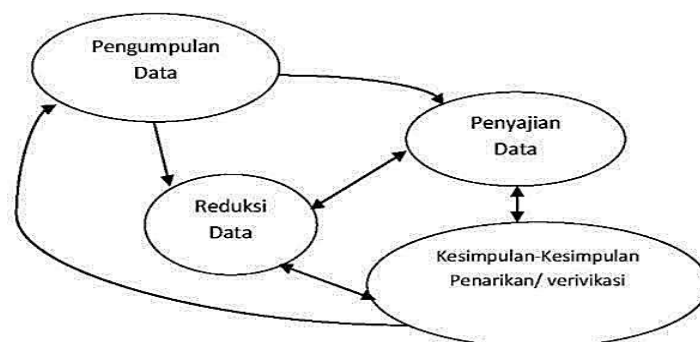

Figure 1. Components in Data Role (interactive model)

Source triangulation, namely testing credible data through checking data obtained through several research sources (Pratama, 2022). Triangulation of sources in this study, namely comparing the results of interviews between the main and supporting informants found at MAN 2 Pekanbaru City.

3. Results and Discussion

Management Function SKS Program Process Indicator

Learner Participation

Based on the results of the interview review from key informant (G) said that: “The implementation of the SKS program is planned by selecting grade X students in semester 1”. The same thing was also expressed by key informant (DA) who said that: “Students must take a series of tests in the first semester of grade X, then

mapping and grouping of classes based on their respective ability levels is carried out". Furthermore, key informant (S) said that: "There are differences in implementation time and learning methods for students that are tailored to their respective abilities". The next information is from informant (TI) who said that: "Regarding the SKS program, control is carried out by means of summative assessment, enrichment and remedial so that students can complete their learning time according to the target". The Semester Credit System (SKS) program is implemented specifically as a form of learning service for students who have different abilities and learning speeds. The road map for implementing the SKS program in the Merdeka Curriculum at MAN 2 Pekanbaru City can be seen in the following figure.

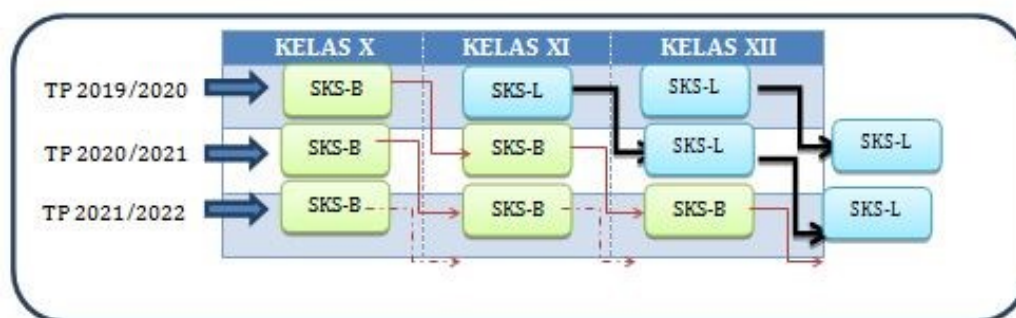

Figure 2. Road Map for Implementing the SKS Program at MAN 2 Pekanbaru City

Based on the results of documentation and observations made, the implementation of the SKS program to monitor the development of students individually, provide direction in the selection of subjects according to interests and abilities, and help design effective learning strategies.

Teacher Involvement

Based on the results of a review of interviews conducted with key informants (G) said that: "Teacher involvement is very important in the SKS program by being included in joint meetings to plan and achieve the objectives of this program". Then, key informant (S) also said that: "In the SKS program, teachers are given workloads and carry out their respective duties and functions". In line with key informant (DA) who said that: "Each teacher runs this SKS program according to their respective roles. Then, the curriculum will observe and control the course of the SKS program".

The same thing was also expressed by informant (TI) who said that: "After being given a workload, teachers must carry out their roles and tasks according to the results of the joint meeting decision. We not only teach according to the schedule, but also have to monitor frequently and provide individualized guidance". Through this professional and collaborative role, teachers become a key element in realizing the effective implementation of the SKS program and are oriented towards developing the maximum potential of students.

Technical guidance at MAN 2 Pekanbaru City is also carried out regularly every year to improve and update teachers' skills. This was conveyed directly by the key informant (DA) who said that: "For teacher preparation, of course we hold workshops to prepare teachers to teach in SKS classes. The same thing was also expressed by informant (TI) who said that: "Before running the SKS program, we teachers first get an understanding to prepare ourselves in organizing this program, it is our responsibility to serve the learning speed of students".



Figure 3. SKS Program Seminar at MAN 2 Pekanbaru City

Related to the implementation of the SKS program at MAN 2 Pekanbaru City is a challenge for teachers in carrying out their role. Teachers are given freedom, improvisation in determining and delivering learning strategies, such as the use of learning resource media, holding additional classes for accelerated SKS class students (PCP) using teaching materials in the form of teaching modules and LKPD.

Teaching Tools

Based on the results of the review of interviews conducted with key informants (DA) said that: "Teaching tools are needed to support the learning process of the SKS program, for this reason a plan for preparing teaching tools is carried out by appealing to all subject teachers". Also added by key informant (S) who said that: "The process of preparing teaching tools is carried out among fellow MGMP to collaborate with each other to determine what learning strategies and models are suitable for each group of students". Then, key informant (DA) said that: "There is monitoring and control of the suitability of the implementation of the SKS program KBM with the teaching tools that have been prepared".

Other information was revealed by informant (TI) who said that: "We are encouraged to develop teaching modules that can be used by both regular and accelerated learners, so there must be adjustments in terms of content and depth of material". It is important for teachers to have a good understanding of curriculum principles, learning outcomes and how to develop effective and flexible teaching

tools. Training and mentoring for teachers in developing teaching tools in accordance with the SKS program is also key to the success of this program.

Teaching tools are designed to enable students to learn independently with systematic materials, exercises and self-evaluation, as well as enrichment materials for students who have more interest and ability, and remedial programs for those who need additional support. As expressed by the key informant (DA) who said that: "Every teacher is asked to prepare teaching tools by following the system and structure of the applicable curriculum, namely the Merdeka Curriculum". Other information was also added by key informant (S) who said that: "For the preparation of teaching tools, it is adjusted by following the structure of the Merdeka Curriculum, because this program is a learning service, so it still follows the applicable curriculum". Furthermore, informant (TI) said that: "All teachers attend training in the preparation of teaching tools and gather with their MGMP to collaborate with each other to prepare teaching tools according to the needs of students".



Figure 4. Training in the Preparation of Teaching Materials at MAN 2 Pekanbaru City

The implementation of the SKS program in madrasas can run more effectively with standardized and integrated teaching tools in differentiated learning.

Facilities/Technology

Based on the results of the interview review with key informants (G) said that: "Madrasahs are very supportive by providing adequate facilities and technology, good quality human resources and one-stop integrated services (PTSP) to facilitate the process of administering the SKS program". Furthermore, informant (N) said that: "The provision of facilities and technology in the SKS program has not escaped the attention and support of the regional office of the Ministry of Religion, the madrasa committee and parents". Then, key informant (S) also said that:

"Adequate facilities and technology are provided in the process of preparing teaching tools for teachers and the learning process for students in the SKS program".

Also added by key informant (DA) who said that: "The curriculum periodically monitors and follows up during the implementation of the SKS program, whether the facilities and technology are used according to the flow of its objectives or not". This shows that the success of the SKS program is not only determined by the availability of technology, but also the ability of teachers to utilize the facilities/technology that have been provided. Based on the results of the observations, the researcher found that MAN 2 Pekanbaru City has implemented digital-based education services by providing facilities and technology both in terms of administration and in the learning process.

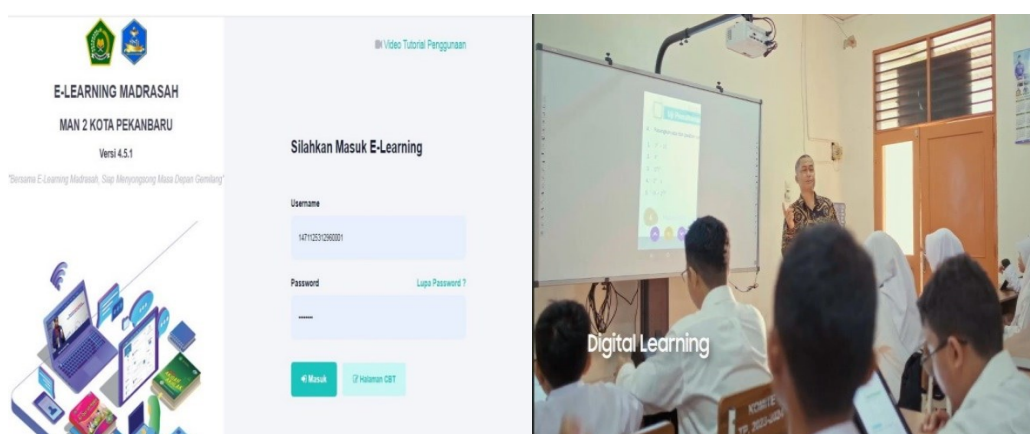

Figure 5. Digital Learning of the SKS Program at MAN 2 Pekanbaru City

Other supporting factors in the learning process of the SKS program are providing more varied media and using available facilities and technology to make it easier for students to understand the material presented.

Management Function Indicators of Achievement of SKS Program Learners

Study Period

Based on the results of the interview review of key informants (G) said that: "A plan to determine the study period for the SKS program is 2 years for fast learners, and 3 years for normal and slow learners". Furthermore, key informant (DA) also said that: "First, a mapping of students with different abilities is carried out, each of which has a different way and time to complete their studies". Then, additional information from key informant (S) who said that: "Madrasahs set acceleration criteria and completion criteria that must be met by students to set the maximum time limit for completing studies to ensure measurable targets and control". This provides a different learning culture in terms of the mechanism for implementing the SKS program, especially in the SKS service program for accelerating the two-

year study period. The two-year study period for students with above-average intelligence levels is called the accelerated SKS class (PCP), while the three-year study period for students with average intelligence levels is called the regular class. For more details regarding the study period of SKS program students, please see the table below:

Table 1. Study Period of the SKS Program Implementation

	Study Period 3 Years (Regular)		2 Year Study Period (Acceleration)			
	Semester	Semester		Semester	Semester	Semester
First year	I/ 6	II/6	First year	I/ 4	II/ 4	III/ 4
Second year	III/ 6	IV/ 6	Second year	IV/ 4	V/ 4	VI/ 4
Third year	V/ 6	VI/ 6	-	-	-	-
Total	36 Month		Total	24 Month		

Based on the results of observations, the implementation of the short semester (SP) in the implementation of the SKS program at MAN 2 Pekanbaru City is not implemented, because in completing the learning process, tutoring has been carried out in the afternoon.

Grade Point Average (GPA)

Based on the results of the review of interviews with key informants (DA), it is known that: “For the weighting of GPA scores, efforts are first made to understand targets, learning strategies and monitoring academic progress, as well as determining the completeness criteria that must be met by students”. Furthermore, according to key informant (S) that: “It takes cooperation between various components in a structured and systematic manner that supports students in planning and achieving their GPA targets in the SKS program”.

Then, informant (TI) said that: “GPA determination in the SKS program must involve real action and a continuous process to realize the GPA target, so that it is maximally pursued, and follow-up is carried out for students who obtain a GPA below the target”. Therefore, GPA is one of the indicators to assess the level of success of students, as well as the basis for determining graduation, awards and continuation of education to higher education. Based on the results of observations, as a guideline for calculating GPA at MAN 2 Pekanbaru City can be seen from the following Table.

Table 2. Example of Calculation of Achievement Index (IP) for SKS Program at MAN 2 Pekanbaru City

No	Subject	Study Load	Summative Number	SAS Number	Average (N)	B x N
Group A (General)						
1.	Pendidikan Agama dan Budi Pekerti	3	80	82	81	243
2.	Pendidikan Pancasila dan Kewarganegaraan	2	80	80	80	160
3.	Bahasa Indonesia	4	85	83	84	336
4.	Matematika	4	82	80	81	324

No	Subject	Study Load	Summative Number	SAS Number	Average (N)	B x N
5.	Sejarah Indonesia	2	76	78	77	154
6.	Bahasa Inggris	2	78	80	79	158
Group B (General)						
7.	Seni Budaya	2	72	76	74	148
8.	Pendidikan Jasmani, Olah Raga, dan Kesehatan	3	83	85	84	252
9.	Prakarya dan Kewirausahaan	2	80	80	80	160
Group C (Specialization)						
10.	Matematika	3	80	82	81	243
11.	Fisika	3	79	81	80	240
12.	Kimia	3	82	82	82	246
13.	Biologi	3	85	83	84	252
14.	Ekonomi	3	80	80	80	240
15.	Bahasa Inggris	3	78	76	77	231
Total		42				3387

As for the assessment of learning outcomes for the SKS program at MAN 2 Pekanbaru City, namely using the Achievement Index (IP) with the formula:

$$IP = \frac{3387}{42} = 80,64 \approx 81$$

Information:

IP = Achievement Index

Ni = Average value

Bi = Study load for each subject (JP)

Report Card

Based on the results of the interview review with the key informant (DA) said that: "The preparation of report cards in the SKS program is planned to be more individual, flexible and oriented towards the competency achievement process, not just numerical values like the regular system". Then, added by the key informant (S) who said that: "Each homeroom teacher who has been appointed in organizing the SKS program, is given convenience in terms of time and filling out report cards for students according to their respective learning outcomes". This was confirmed by the informant (TI) who also said that: "The preparation of report cards in the SKS program is carried out through systematic and structured stages, and monitoring and control are carried out each semester on student learning outcomes based on the report cards". MAN 2 Pekanbaru City uses a digitalization system in the form of the RAPODIG application. The following is the home page displayed on RAPODIG MAN 2 Pekanbaru City.



Figure 6. Home Page of DAPODIK MAN 2 Pekanbaru City

Impact Indicator Management Function on Institutions

Alumni Data

Based on the results of the interview review with key informants (G) said that: "A comprehensive and sustainable alumni information collection system was designed in a structured manner". Then, key informants (DA) said that: "The data collection mechanism involves collecting contact information, further education paths (study programs and universities), employment status (industry field, company name, position), and potential alumni involvement in madrasah activities". Furthermore, key informants (S) also said that: "All data is classified and archived by BK teachers neatly, both in manual and digital form to support the evaluation of the SKS program and the development of alumni networks in the future".

Accreditation

Based on the results of the interview review with key informants (G) said that: "The preparation of accreditation is carried out systematically and based on national education quality standards". Then, key informants (DA) said that: "This accreditation process involves a team tasked with coordinating data collection, conducting self-evaluations and ensuring that all accreditation requirements are met before the visitation is carried out by the supervisor". Informant (TI) who also serves as the Head of P2MM said that: "Implementation is carried out by filling out accreditation instruments that contain aspects of management, learning processes, assessments, student services and learning outcomes. The results of this accreditation are the basis for official recognition of the implementation of the SKS program, as well as continuous control and improvement in improving the quality of education services".

The SKS program also contributes to improving accreditation in a school/madrasah supported primarily by scheduling flexibility, the ability to accommodate different learning speeds of students, adequate facilities and infrastructure, a transparent assessment system and professional educators, and especially in the aspects of curriculum management, learning processes and quality of graduates. Educational institutions that are able to demonstrate that the SKS program effectively motivates students, provides learning experiences and improves the quality of education. Schools/madrasahs that successfully achieve SKS program accreditation demonstrate their commitment to providing adaptive, student-centered education and are able to accommodate various learning speeds, thus ultimately improving the quality of education.



Figure 8. Accreditation Certificate of MAN 2 Pekanbaru City

This shows that student participation in the SKS program is highly dependent on the level of independence of each and is responsible for their academic choices, and the graduation of students in the SKS program is determined by the completion of all subjects completely and ends with PAS/exams as summative assessments held every semester. The implementation of the SKS program in the Merdeka Curriculum at MAN 2 Pekanbaru City is almost the same as the 2013 Curriculum, only the lessons or materials are shorter and denser, and there is the implementation of P5PPRA. To determine the graduation criteria, it is carried out by completing all subjects completely and ending with a national madrasah assessment as a summative assessment. Thus, students are declared to have graduated from the educational unit if (1) they complete all learning programs; (2) they obtain good attitude/behavior scores; and (3) they pass the madrasah assessment as stated in the previous section.

Based on the above information, it can be concluded that the implementation of the SKS program at MAN 2 Pekanbaru City is a realization of the planning stage that has been previously determined and is in accordance with the Decree of the Director General of Pendis No. 2852 of 2019 concerning Technical Instructions for the Implementation of SKS at Madrasah Aliyah (MA), and uses teaching modules as

learning materials for the SKS program and is in accordance with the control stages contained in the technical instructions for implementing SKS for Madrasah Aliyah, the evaluation results are useful for improvement and obtaining assistance from the government to make improvements and improvements to the implementation of SKS.

4. Conclusion

Based on the focus of the research, data presentation and research findings in the field through documentation studies, observations and interviews, the first conclusion can be drawn. The function of the SKS program process indicator management in the Independent Curriculum at MAN 2 Pekanbaru City, namely examining the form of planning, organizing, implementing and controlling student participation which is the main subject and object in the SKS program, the involvement of teachers as service providers for the SKS program, the preparation of teaching materials in more depth, and adequate facilities/technology to organize the SKS program at this madrasah. Second, the management function of achievement indicators for students in the SKS program in the Independent Curriculum at MAN 2 Pekanbaru City, namely reviewing the form of planning, organizing, implementing and controlling the study period taken by students in the SKS program, determining the Cumulative Achievement Index (IPK), and compiling report cards as a form of learning outcomes for the SKS program, and the third is the management function of impact indicators on the institution of the SKS program in the Independent Curriculum at MAN 2 Pekanbaru City, namely reviewing the form of planning, organizing, implementing and controlling the compilation of data on alumni of the SKS program accepted at favorite universities, as well as compiling and determining madrasah accreditation so that the SKS program becomes a superior academic program for madrasahs.

References

- Aina, H. K. (2023). Penerapan Kurikulum Merdeka dengan Sistem SKS pada Mata Pelajaran IPS Kelas VII MTs Negeri 7 Malang [Universitas Islam Negeri Maulana Malik Ibrahim Malang]. In *etheses UIN Malang*. <http://etheses.uin-malang.ac.id/58834/>.
- Bunga, B. S. (2023). Perception of History Teachers of Independent Learning Curriculum at MAN 2 Pekanbaru. *Santhet (Jurnal Sejarah Pendidikan Dan Humaniora)*, 8(1), 76–80. <https://doi.org/10.36526/santhet.v8i1.3066>.
- Depdiknas. (2003). *Undang-Undang RI No. 20 Tahun 2003 Tentang Sistem Pendidikan Nasional*. https://jdih.kemdikbud.go.id/sjih/siperpu/dokumen/salinan/UU_tahun2003_nomor020.pdf
- Dirjen Pendis. (2019). *Surat Keputusan Direktur Jenderal Pendidikan Islam Nomor 6633 Tahun 2019 tentang Madrasah Penyelenggara SKS*.
- Eko, W., & Riayatul, H. (2022). Manajemen Kurikulum Sistem Kredit Semester
-

-
- dalam Meningkatkan Mutu Pendidikan di MAN 1 Kota Probolinggo. *Southeast Asian Journal of Islamic Education Management*, 3(2), 233–246. <https://doi.org/10.21154/sajiem.v3i2.104>.
- Fadhila, N. I., Edwar, P. L., Marno, & Nur, M. A. (2023). Manajemen Kurikulum melalui SKS By School dalam Meningkatkan Efisiensi Pendidikan dan Keberhasilan Peserta Didik. *Pendas : Jurnal Ilmiah Pendidikan Dasar*, 08(02). <https://journal.unpas.ac.id/index.php/pendas/article/view/8755>.
- Fitriyanti, E. S., & Sholeh, M. (2023). Manajemen Kurikulum Merdeka dalam Meningkatkan Potensi Peserta Didik di Yayasan Sekolah Alam Citra Insani (SACI) Lamongan. *Jurnal Inspirasi Manajemen Pendidikan*, 10(4), 788–797. <https://ejournal.unesa.ac.id/index.php/inspirasi-manajemen-pendidikan/article/view/55920>
- Moleong, L. J. (2019). *Metode Penelitian Kualitatif*. Remaja Rosdakarya.
- Naufal, H., Irkhamni, I., & Yuliyani, M. (2020). Penelitian Penerapan Program Sistem Kredit Semester Menunjang Terealisasinya Merdeka Belajar di SMA Negeri 1 Pekalongan. *Jurnal Konferensi Ilmiah Pendidikan*, 1(1), 141–148. <https://proceeding.unikal.ac.id/index.php/kip/article/view/493>
- Nisa, M., & Pramono, D. (2023). Kultur Belajar Sistem Kredit Semester di SMA: Perlukah dalam Implementasi Kurikulum Merdeka? *Jurnal Ilmiah Profesi Pendidikan*, 8(3), 1271–1281. <https://doi.org/10.29303/jipp.v8i3.1410>
- Permendikbud, R. I. (2014). *Peraturan Menteri Pendidikan dan Kebudayaan Republik Indonesia Nomor 158 Tahun 2014 tentang Penyelenggaraan Sistem Kredit Semester pada Pendidikan Dasar dan Pendidikan Menengah*. <https://www.kemdikbud.go.id>
- Pratama, F. A. (2022). Implementasi Program Sistem Kredit Semester di Sekolah Menengah Atas Negeri 1 Bantul. *Jurnal Spektrum Analisis Kebijakan Pendidikan*, 11(4), 33–48.
- Radjak, T. S., Yahiji, K., & Damopolii, M. (2023). Fungsi Manajemen dalam Pengelolaan Pembelajaran pada Kurikulum Merdeka di MA Muhammadiyah Kota Gorontalo. *Journal of Islamic Education Managemet Research*, 2(2), 25–35.
- Sasmito, P., Mujamil Qomar, & Agus Zaenul Fitri. (2022). Management Curriculum Through The Semester Credit System (SKS) in The Competency Standards to Improve The Quality of Education. *International Journal of Science, Technology & Management*, 3(1), 113–124. <https://doi.org/10.46729/ijstm.v3i1.443>
- Sugiyono. (2022). *Metode Penelitian Kuantitatif, Kualitatif dan R&D*. CV. Alfabeta.
- Sutri, R., & Miftahur, R. (2023). Analisis Kebijakan Implementasi Kurikulum Merdeka di Madrasah. *Bustanul Ulum Journal of Islamic Education*, 1(1), 97–114. <https://doi.org/10.62448/bujie.v1i1.23>.
- Yunus, M. A., Luneto, B., & Anwar, H. (2021). Fungsi Manajemen dalam Pengelolaan Kurikulum (Studi Manajemen Kurikulum Tingkat Satuan Pendidikan Sekolah Dasar). *Jurnal Pendidikan Islam*, 4(2), 17–26. <https://journal.iaingorontalo.ac.id/index.php/alminhaj/article/view/2601>.
- Zamista, A. A., & Deswita, P. (2023). Perceptions of Indonesian Teachers on The Implementation of “Merdeka” Curriculum. *Wiyata Dharma: Jurnal*
-

Penelitian Dan Evaluasi Pendidikan, 11(1), 13–25.
<https://doi.org/10.30738/wd.v11i1.15611>.

Zuchri, A. (2021). *Metode Penelitian Kualitatif* (1st ed.). CV. Syakir Media Press.

How to cite this article:

Yunizahri, R., Putra, M. J. A., & Gimin. (2026). Management of the Semester Credit System (SKS) Program in the Merdeka Curriculum at MAN 2 Pekanbaru City. *Journal of Educational Sciences*, 10(1), 178-192.
